

Yesteryears Millwork

HOME DESIGN BOOK

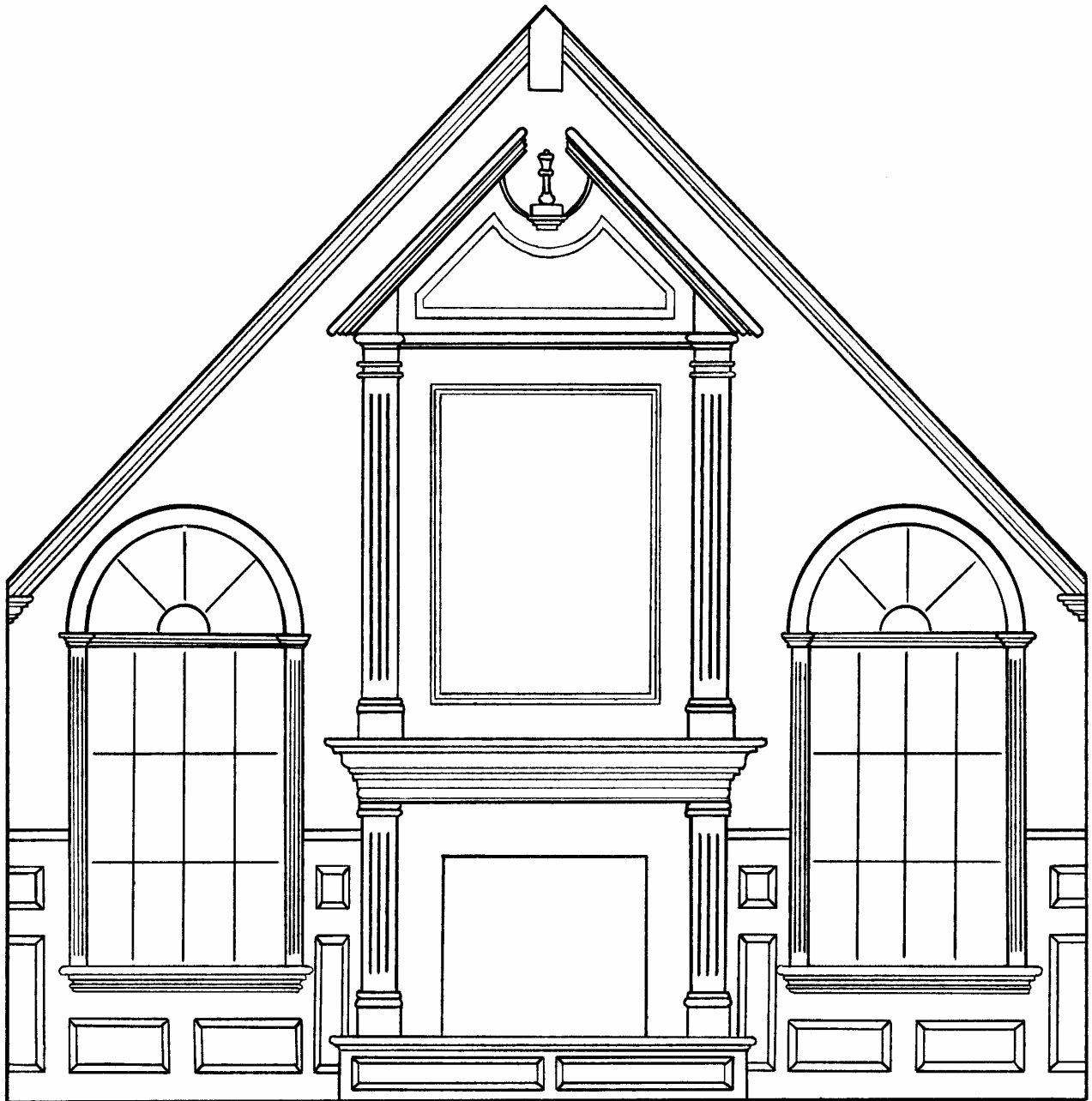

WWW.YESTERYEARS MILLWORK.COM



CLIENT : CARMEL DEVELOPMENT	DATE :
ADDRESS :	PHONE :
JOB ADDRESS : 1331 17 MILE DRIVE, PEBBLE BEACH	FAX :
COMMENTS :	JOB/PHONE :

YESTERYEARS MILLWORK / ESTIMATE PG 1 OF 7

LF / EA	DESCRIPTION OF ITEM	DETAILS	PRICE	AMOUNT
1				
2	* "PAINT-GRADE" BASE, CASING, STOOL-APRON *			
3				
4	1085 #1341 PG BASE	Z1		
5				
6	2468 #1265 PG CASING	Z2		
7				
8	166 #1965 PG STOOL-APRON	Z3		
9				
10	* "PAINT-GRADE" JAMB FOR CASED OPENINGS *			
11				
12	84 1x8 S4S PG JAMB	J3		
13				
14				
15	* "PAINT-GRADE" FLAT MULLION MATERIAL *			
16	3 1/4 4x8 MDF	M1		
17				
18	* "PAINT-GRADE" FLEX ARCHES IN HOME *			
19	* ARCHES BELOW TO BE #1265 "PAINT-GRADE" CASING *	Z2		
20	2 EYE BROW ARCHES / RADIUS OF 48" / 6' L			
21	1 EYE BROW ARCH / RADIUS OF 54" / 7' L			
22	2 EYE BROW ARCHES / RADIUS OF 60" / 8' L			
23	1 EYE BROW ARCH / RADIUS OF 72" / 10' L			
24				
25	* "PAINT-GRADE" FLEX STRAIGHT-STOCK *			
26	18 FLEX #1341 PG BASE	Z1		
27	13 FLEX #1965 PG STOOL/APRON	Z3		
28				
29				
30				

WE WILL FURNISH THE ABOVE ITEMS WITHIN ____ % OF TOTAL ESTIMATE IS GOOD FOR ____ DAYS FROM THIS DATE ____
 F.O.B. _____ ACCEPTED BY : _____

WWW.YESTERYEARS MILLWORK.COM

	SUB TOTAL PER PAGE
	SUB TOTAL ALL PAGES
	SALES TAX
	GRAND TOTAL



CLIENT : CARMEL DEVELOPMENT **DATE :**
ADDRESS : **PHONE :**
JOB ADDRESS : 1331 17 MILE DRIVE, PEBBLE BEACH **FAX :**
COMMENTS : **JOB/PHONE :**

YESTERYEARS MILLWORK / ESTIMATE PG 2 OF 7

LF / EA	DESCRIPTION OF ITEM	DETAILS	PRICE	AMOUNT
1				
2	* "CHERRY" BASE, CASING, STOOL-APRON IN LIBRARY *			
3				
4	64 #1341 "CHERRY" BASE	Z1		
5				
6	142 #1265 "CHERRY" CASING	Z2		
7				
8	18 #1965 "CHERRY" STOOL-APRON	Z3		
9				
10	* "CHERRY" CEILING DETAILS IN LIBRARY *			
11	72 (BEAM FRIEZE) 1140 "CHERRY"	B1		
12	72 (BEAM FRIEZE) 1x6 S4S			
13	72 (BEAM FRIEZE) 1920			
14	144 (INNER BEAMS) 1140	B2		
15	144 (INNER BEAMS) 1x6 S4S			
16	72 (INNER BEAMS) 1918			
17	12 (BEAM INTERSECTION BLOCKS) 1915 "CHERRY"	B3		
18				
19	* "CHERRY" T&G paneled wainscot in library *			
20	8 1/4" 4x8 MDF	R1 & R2		
21	278 1x4 S4S "CHERRY"			
22	152 1x6 S4S			
23	64 #1400			
24	64 #1609			
25	440 #1615			
26	696 L-1622			
27	64 #1341			
28				
29				
30				

WE WILL FURNISH THE ABOVE ITEMS WITHIN ____ % OF TOTAL ESTIMATE IS GOOD FOR ____ DAYS FROM THIS DATE ____
 F.O.B. _____ ACCEPTED BY : _____

WWW.YESTERYEARS MILLWORK.COM

	SUB TOTAL PER PAGE	
	SUB TOTAL ALL PAGES	
	SALES TAX	
	GRAND TOTAL	



CLIENT : CARMEL DEVELOPMENT DATE :
 ADDRESS : PHONE :
 JOB ADDRESS : 1331 17 MILE DRIVE, PEBBLE BEACH FAX :
 COMMENTS : JOB/PHONE :

YESTERYEARS MILLWORK / ESTIMATE PG 3 OF 7

LF / EA	DESCRIPTION OF ITEM	DETAILS	PRICE	AMOUNT
1				
2	* "PAINT-GRADE" CEILING DETAILS IN HOME *			
3				
4	{ FOYER }			
5	84 (PERIMETER) 1605	C3		
6	84 () 1141			
7	84 () 1241			
8	48 (RECESS) 1140	C4		
9	48 () 1x4 S4S			
10	48 () 1234			
11				
12	{ POWDER ROOM }			
13	38 1141	C2		
14	38 1241			
15				
16	{ LIVING ROOM }			
17	72 (PERIMETER) 1141	C2		
18	72 () 1241			
19	60 (RECESS) 1140	C4		
20	60 () 1x4 S4S			
21	60 () 1234			
22				
23	{ DINING ROOM }			
24	68 (PERIMETER) 1141	C2		
25	68 () 1241			
26	56 (RECESS) 1140	C4		
27	56 () 1x4 S4S			
28	56 () 1234			
29				
30				

WE WILL FURNISH THE ABOVE ITEMS WITHIN ____ % OF TOTAL ESTIMATE IS GOOD FOR ____ DAYS FROM THIS DATE ____
 F.O.B. _____ ACCEPTED BY : _____

WWW.YESTERYEARS MILLWORK.COM

SUB TOTAL PER PAGE	
SUB TOTAL ALL PAGES	
SALES TAX	
GRAND TOTAL	



CLIENT : CARMEL DEVELOPMENT **DATE :**
ADDRESS : **PHONE :**
JOB ADDRESS : 1331 17 MILE DRIVE, PEBBLE BEACH **FAX :**
COMMENTS : **JOB/PHONE :**

YESTERYEARS MILLWORK / ESTIMATE PG 4 OF 7

1	LF / EA	DESCRIPTION OF ITEM	DETAILS	PRICE	AMOUNT
2		* "PAINT-GRADE" CEILING DETAILS IN HOME *			
3					
4		{ BUTLER'S PANTRY }			
5	32	1141	C2		
6	32	1241			
7					
8		{ MAIN GALLERY HALLS }			
9	118	1141	C2		
10	118	1241			
11					
12		{ KITCHEN / NOOK }			
13	88	1141	C2		
14	88	1241			
15					
16		{ FAMILY ROOM }			
17	94	1141	C2		
18	94	1241			
19					
20		{ GAME ROOM }			
21	74	1141	C2		
22	74	1241			
23					
24		{ LAUNDRY ROOM }			
25	48	1141	C1		
26					
27					
28					
29					
30					

WE WILL FURNISH THE ABOVE ITEMS WITHIN ____ % OF TOTAL
 ESTIMATE IS GOOD FOR ____ DAYS FROM THIS DATE ____
 F.O.B. _____ ACCEPTED BY : _____

WWW.YESTERYEARS MILLWORK.COM

SUB TOTAL PER PAGE	
SUB TOTAL ALL PAGES	
SALES TAX	
GRAND TOTAL	



CLIENT : CARMEL DEVELOPMENT	DATE :
ADDRESS :	PHONE :
JOB ADDRESS : 1331 17 MILE DRIVE, PEBBLE BEACH	FAX :
COMMENTS :	JOB/PHONE :

YESTERYEARS MILLWORK / ESTIMATE PG 5 OF 7

	LF / EA	DESCRIPTION OF ITEM	DETAILS	PRICE	AMOUNT
1					
2		* "PAINT-GRADE" CEILING DETAILS IN HOME *			
3					
4		{ MASTER BDRM. }			
5	72	(PERIMETER) 1141	C2		
6	72	() 1241			
7	58	(RECESS) 1140	C4		
8	58	() 1x4 S4S			
9	58	() 1234			
10					
11		{ MASTER BATH }			
12	56	(PERIMETER) 1141	C2		
13	56	() 1241			
14	38	(RECESS) 1140	C4		
15	38	() 1x4 S4S			
16	38	() 1234			
17					
18		{ MSTR. TOILET ROOM }			
19	28	1141	C2		
20	28	1241			
21					
22		{ MASTER W.I. CLOSET }			
23	48	1141	C1		
24					
25					
26					
27					
28					
29					
30					

WE WILL FURNISH THE ABOVE ITEMS WITHIN ____ % OF TOTAL ESTIMATE IS GOOD FOR ____ DAYS FROM THIS DATE ____
 F.O.B. _____ ACCEPTED BY : _____

WWW.YESTERYEARS MILLWORK.COM

SUB TOTAL PER PAGE	
SUB TOTAL ALL PAGES	
SALES TAX	
GRAND TOTAL	



CLIENT : CARMEL DEVELOPMENT **DATE :**
ADDRESS : **PHONE :**
JOB ADDRESS : 1331 17 MILE DRIVE, PEBBLE BEACH **FAX :**
COMMENTS : **JOB/PHONE :**

YESTERYEARS MILLWORK / ESTIMATE PG 6 OF 7

1	LF / EA	DESCRIPTION OF ITEM	DETAILS	PRICE	AMOUNT
2		* "PAINT-GRADE" CEILING DETAILS IN HOME *			
3					
4		{ 2nd FLOOR BALCONY & HALL }			
5	92	(PERIMETER) 1605	C3		
6	92	() 1141			
7	92	() 1241			
8	16	(SKYLIGHT LENSE GRID) 1x4 545	C5		
9	32	() 1313			
10	64	() 1608			
11					
12		{ BDRM. # 1 }			
13	52	1141	C1		
14					
15		{ BATH # 1 }			
16	38	1141	C1		
17					
18		{ BDRM. # 2 }			
19	54	1141	C1		
20					
21		{ BATH # 2 }			
22	36	1141	C1		
23					
24		{ BDRM. # 3 }			
25	58	1141	C1		
26					
27		{ BATH # 3 }			
28	34	1141	C1		
29					
30					

WE WILL FURNISH THE ABOVE ITEMS WITHIN ____ % OF TOTAL
 ESTIMATE IS GOOD FOR ____ DAYS FROM THIS DATE ____
 F.O.B. _____ ACCEPTED BY : _____

WWW.YESTERYEARS MILLWORK.COM

SUB TOTAL PER PAGE	
SUB TOTAL ALL PAGES	
SALES TAX	
GRAND TOTAL	



CLIENT : CARMEL DEVELOPMENT	DATE :
ADDRESS :	PHONE :
JOB ADDRESS : 1331 17 MILE DRIVE, PEBBLE BEACH	FAX :
COMMENTS :	JOB/PHONE :

YESTERYEARS MILLWORK / ESTIMATE PG 7 OF 7

1	LF / EA	DESCRIPTION OF ITEM	DETAILS	PRICE	AMOUNT
2		* "PAINT-GRADE" PANELED WAINSCOT IN HOME *			
3					
4		{ DINING ROOM }			
5	6	1/4" 4x8 MDF "PAINT-GRADE"	R3 & R4		
6	6	3/4" 4x8 MDF			
7	48	1100			
8	48	1610			
9	48	GW-844			
10	192	1605			
11	48	1341			
12					
13		* "PAINT-GRADE" PANELED JAMB OPENINGS IN HOME *			
14					
15		{ LIVING TO ENTRY }			
16	1	1/4" 4x8 MDF "PAINT-GRADE"	J1 & J2		
17	1	3/4" 4x8 MDF			
18	60	1265			
19	84	1603			
20					
21		{ DINING TO ENTRY }			
22	1	1/4" 4x8 MDF "PAINT-GRADE"	J1 & J2		
23	1	3/4" 4x8 MDF			
24	60	1265			
25	84	1603			
26					
27					
28					
29					
30					

WE WILL FURNISH THE ABOVE ITEMS WITHIN ____ % OF TOTAL ESTIMATE IS GOOD FOR ____ DAYS FROM THIS DATE ____ F.O.B. _____ ACCEPTED BY : _____

WWW.YESTERYEARS MILLWORK.COM

	SUB TOTAL PER PAGE	
	SUB TOTAL ALL PAGES	
	SALES TAX	
	GRAND TOTAL	

FALSE BEAM DETAIL

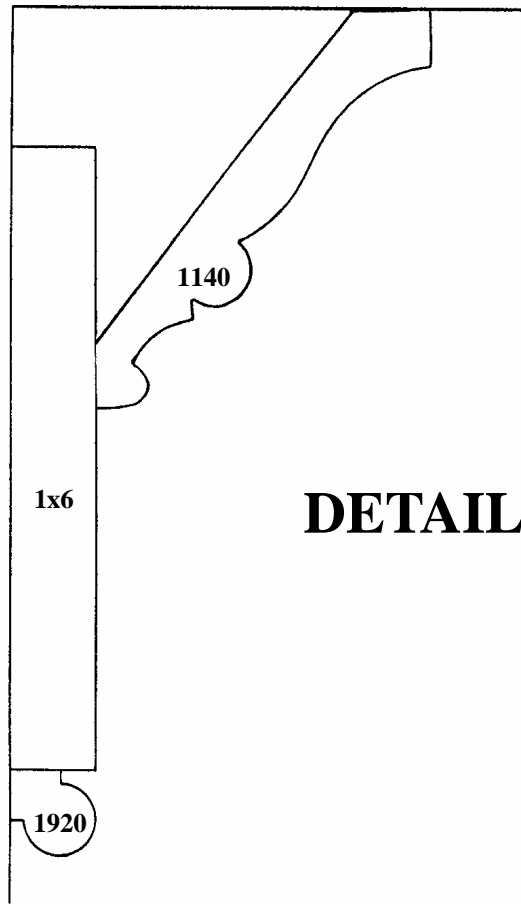

DETAIL B1

DETAIL B2

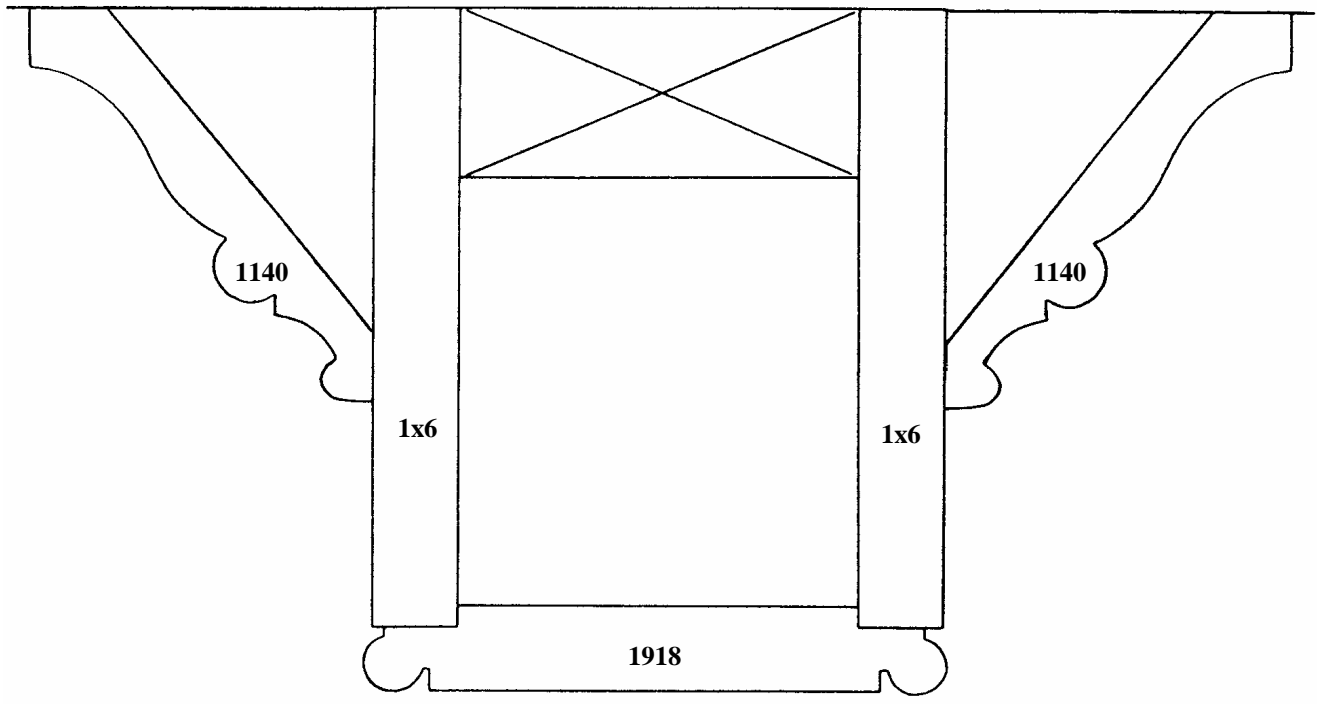

BEAM INTERSECTION DETAIL

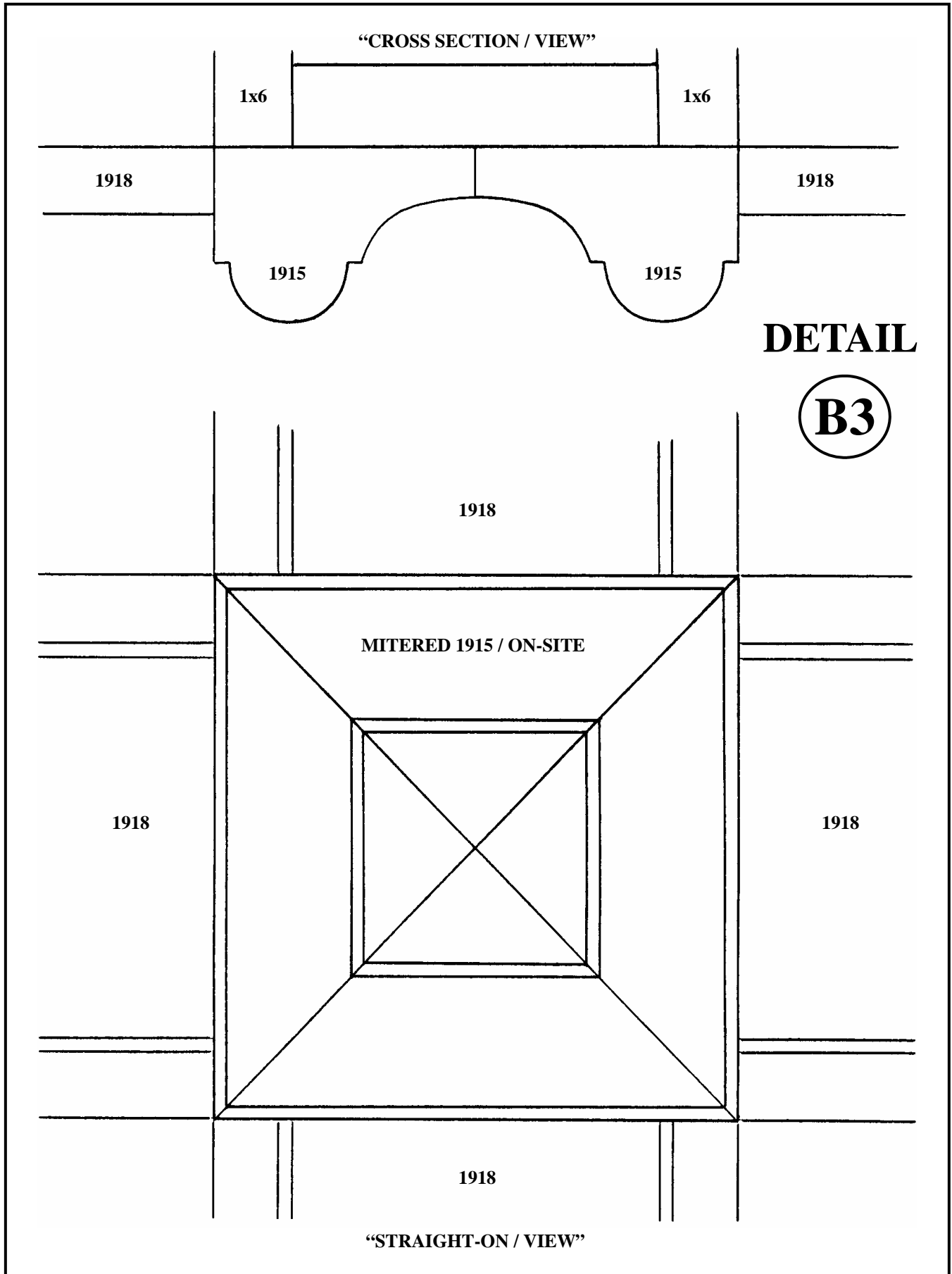

DETAIL

B3

CEILING DETAIL

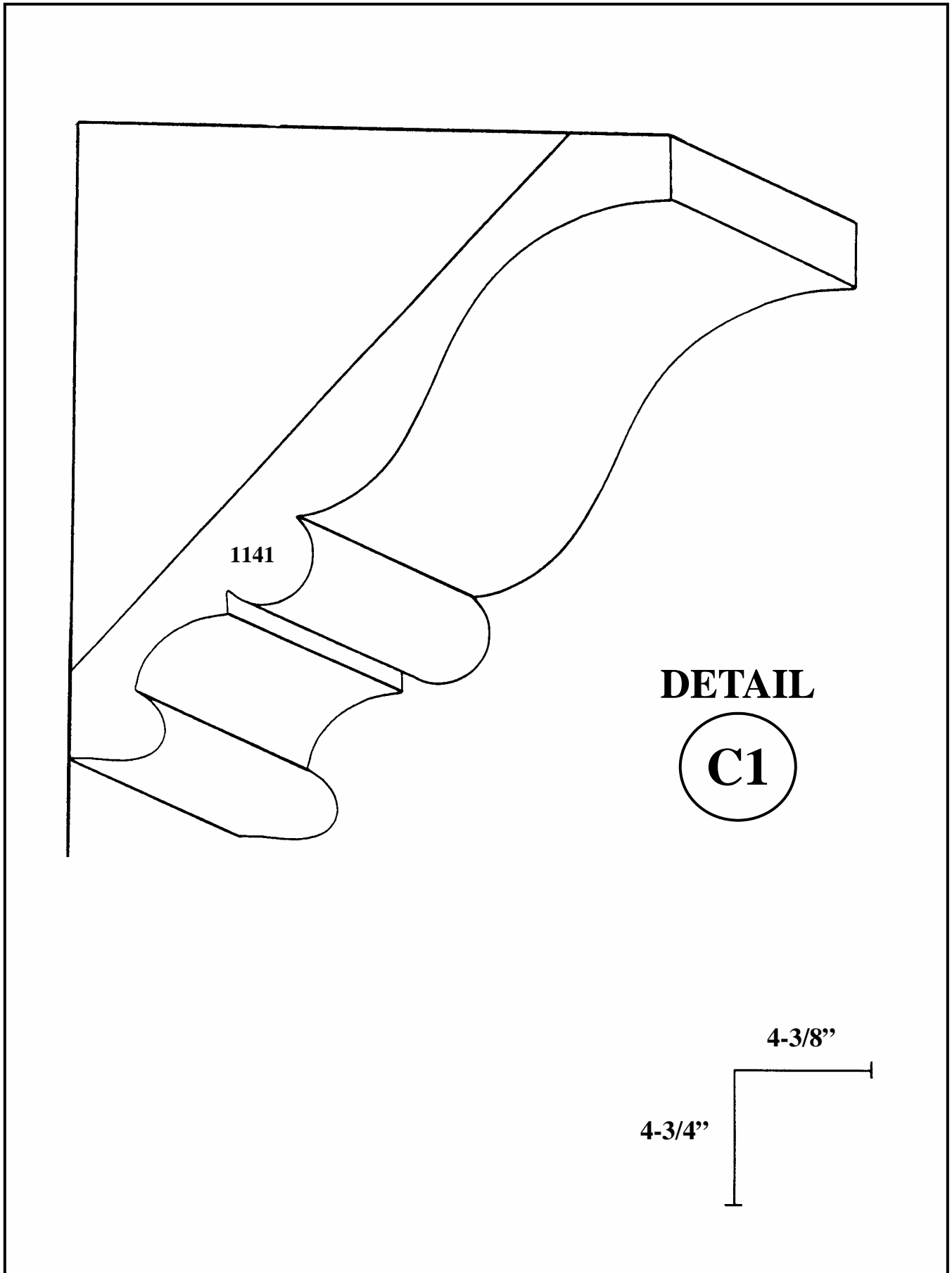

CEILING DETAIL

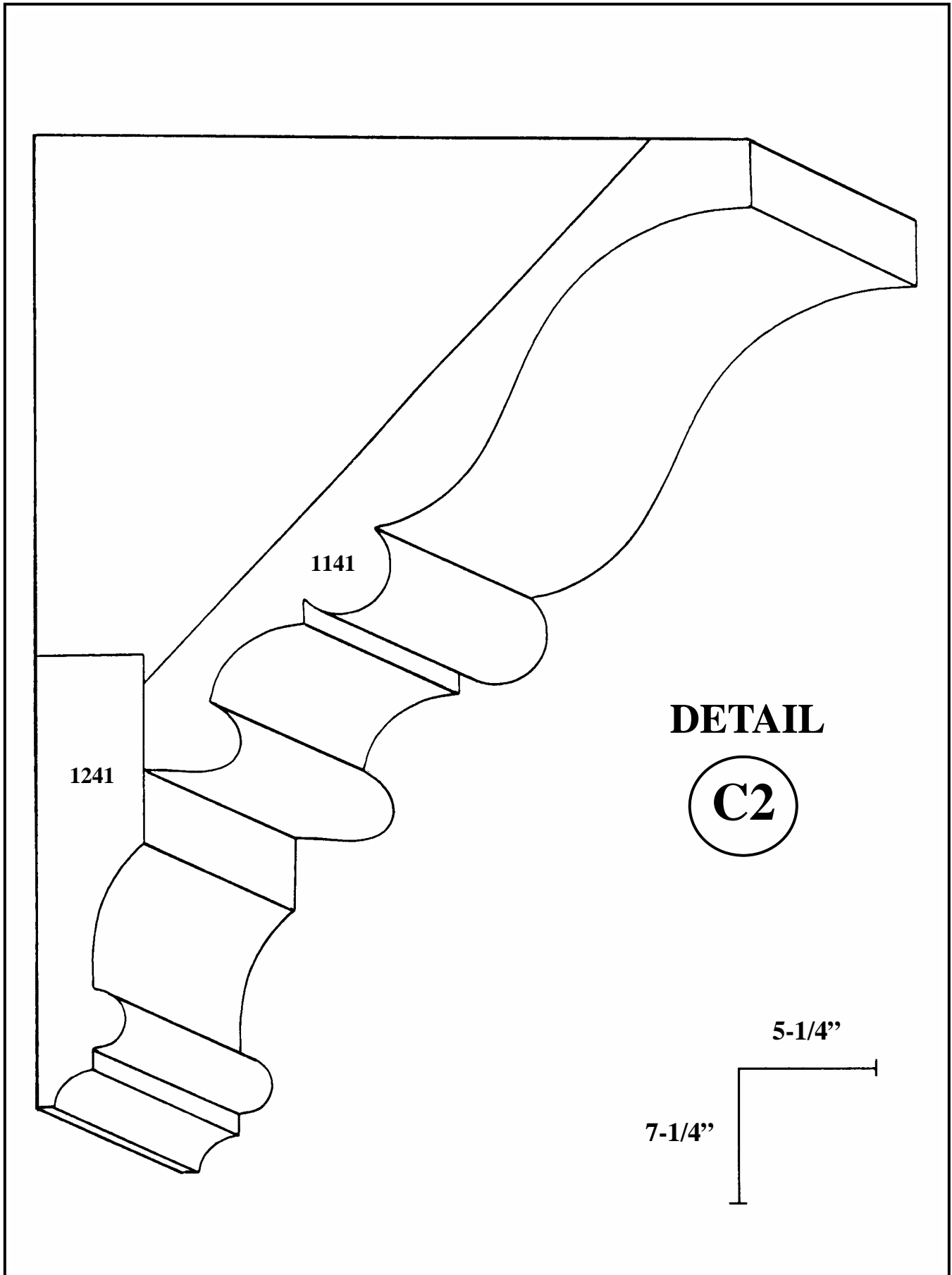

CEILING DETAIL

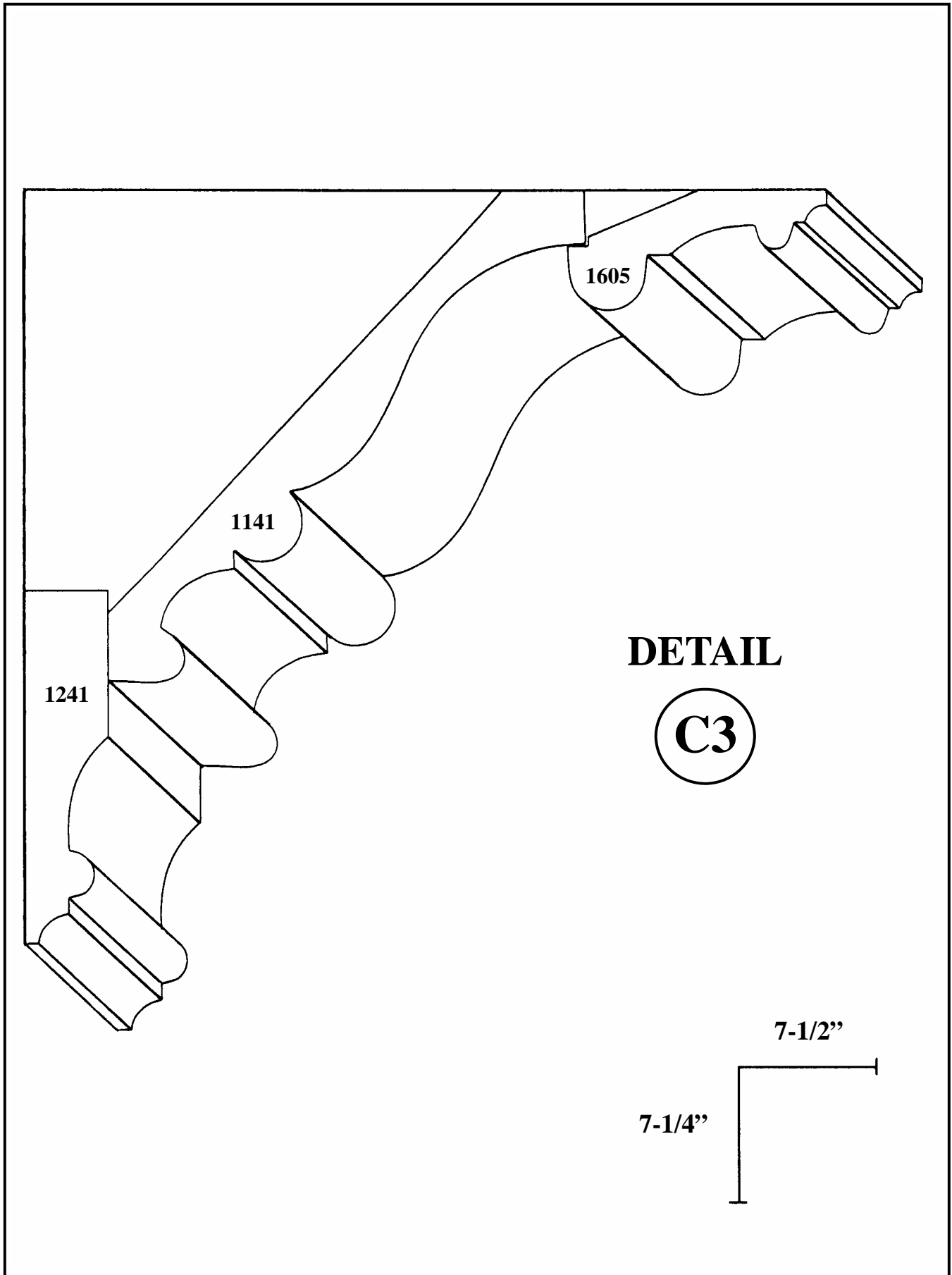

CEILING DETAIL

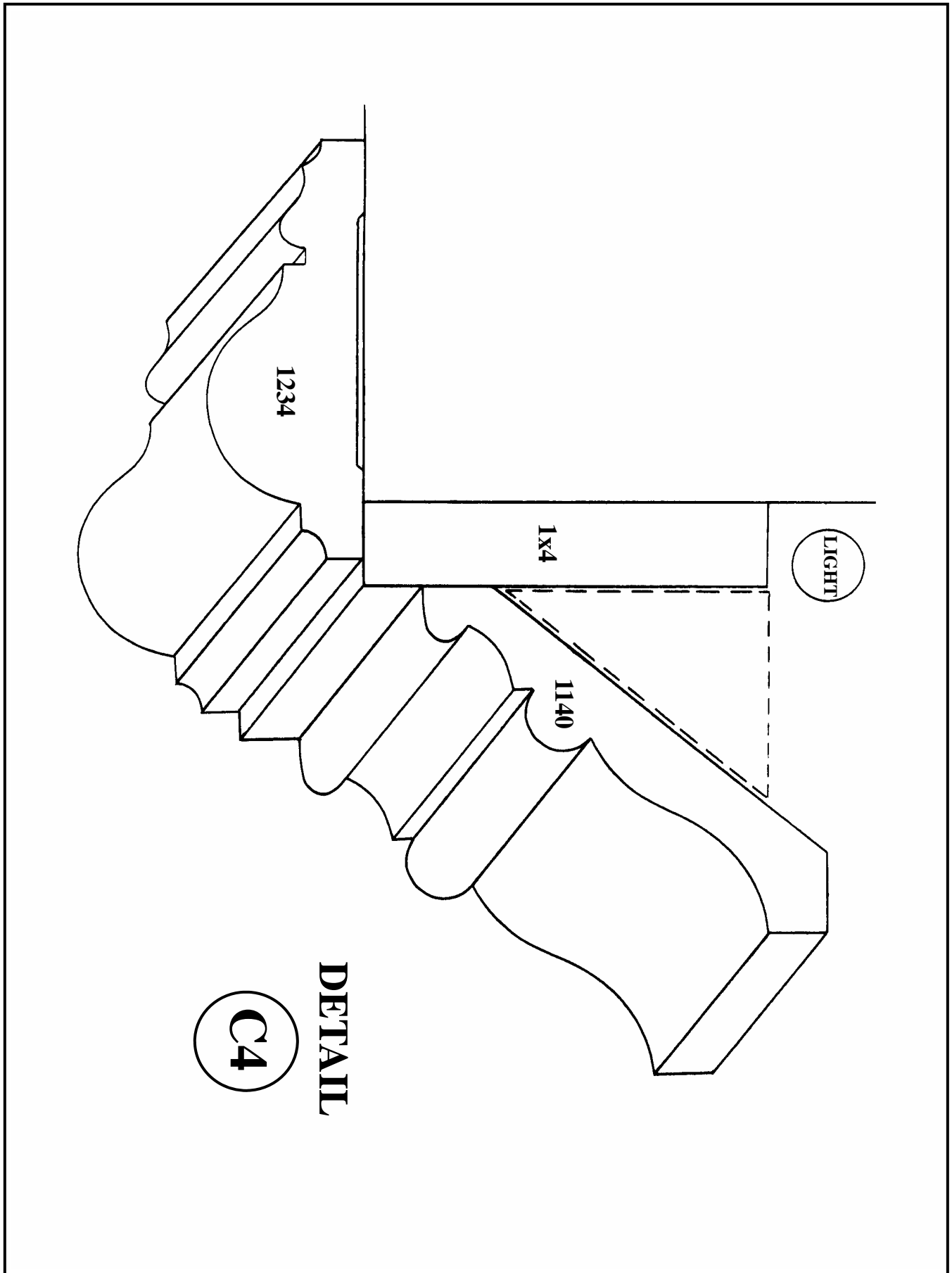

SKY LIGHT / GRID SYSTEM

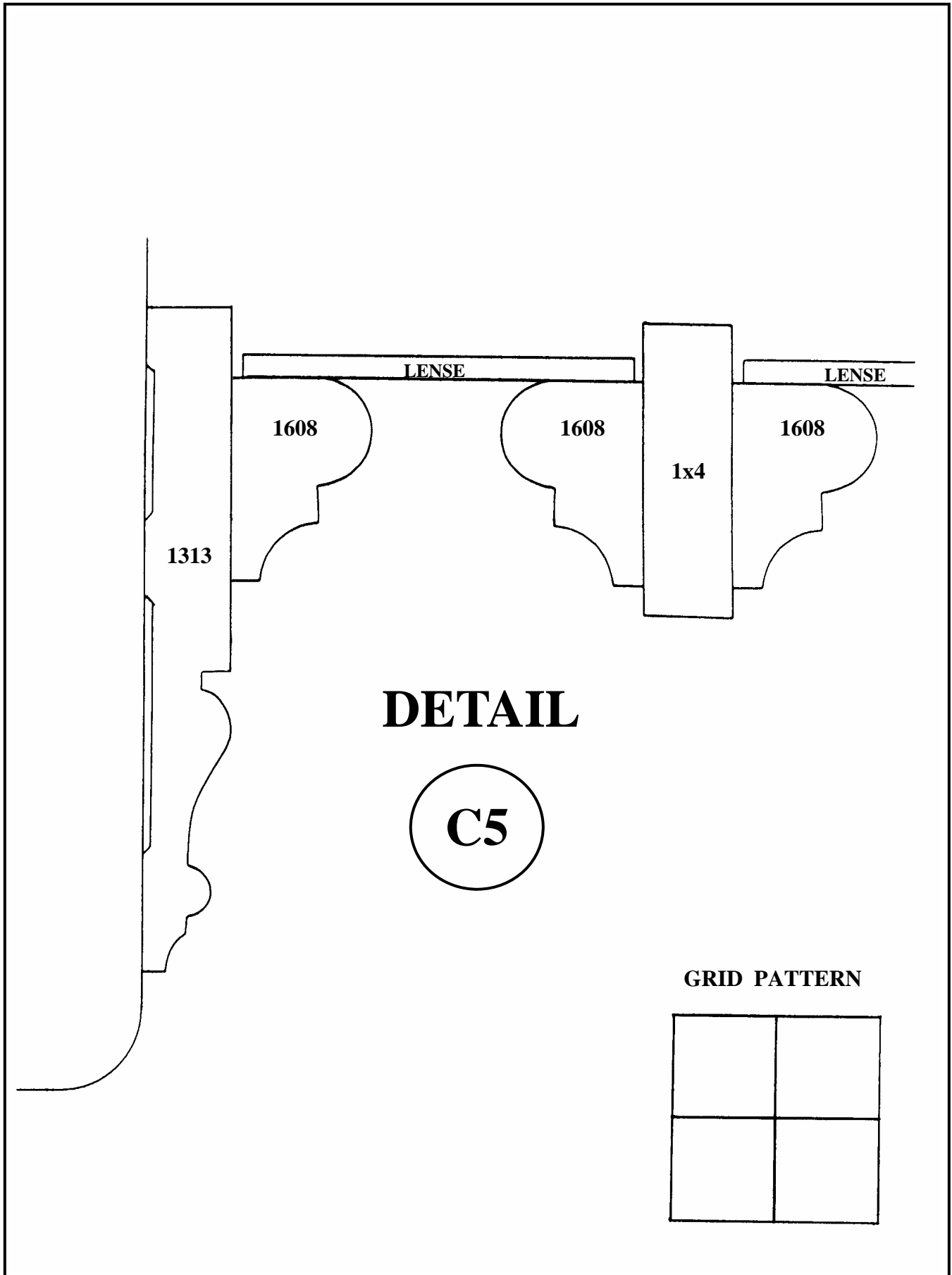

PANELED OPENING DETAIL

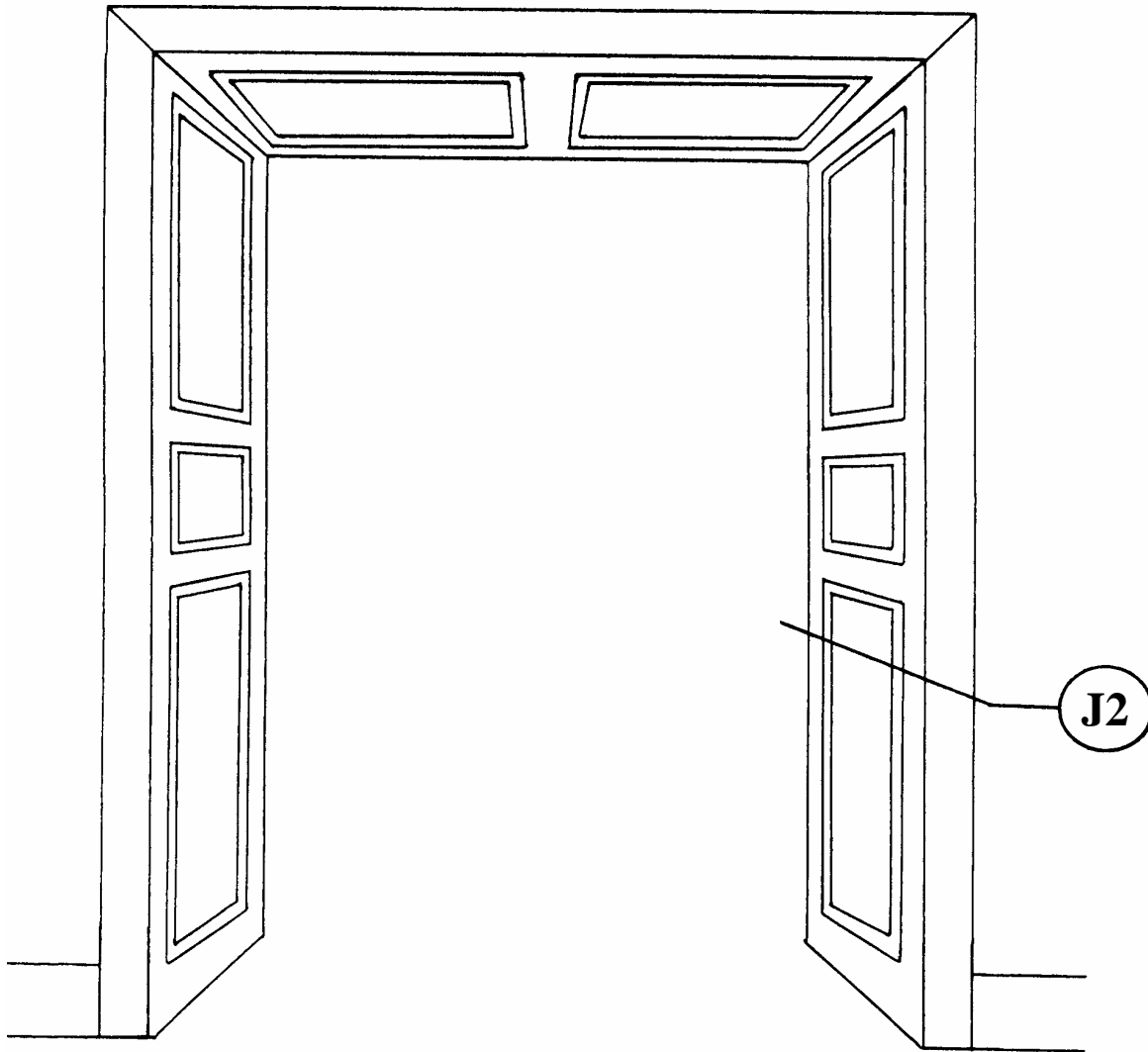

DETAIL

J1

PANELED JAMB DETAIL

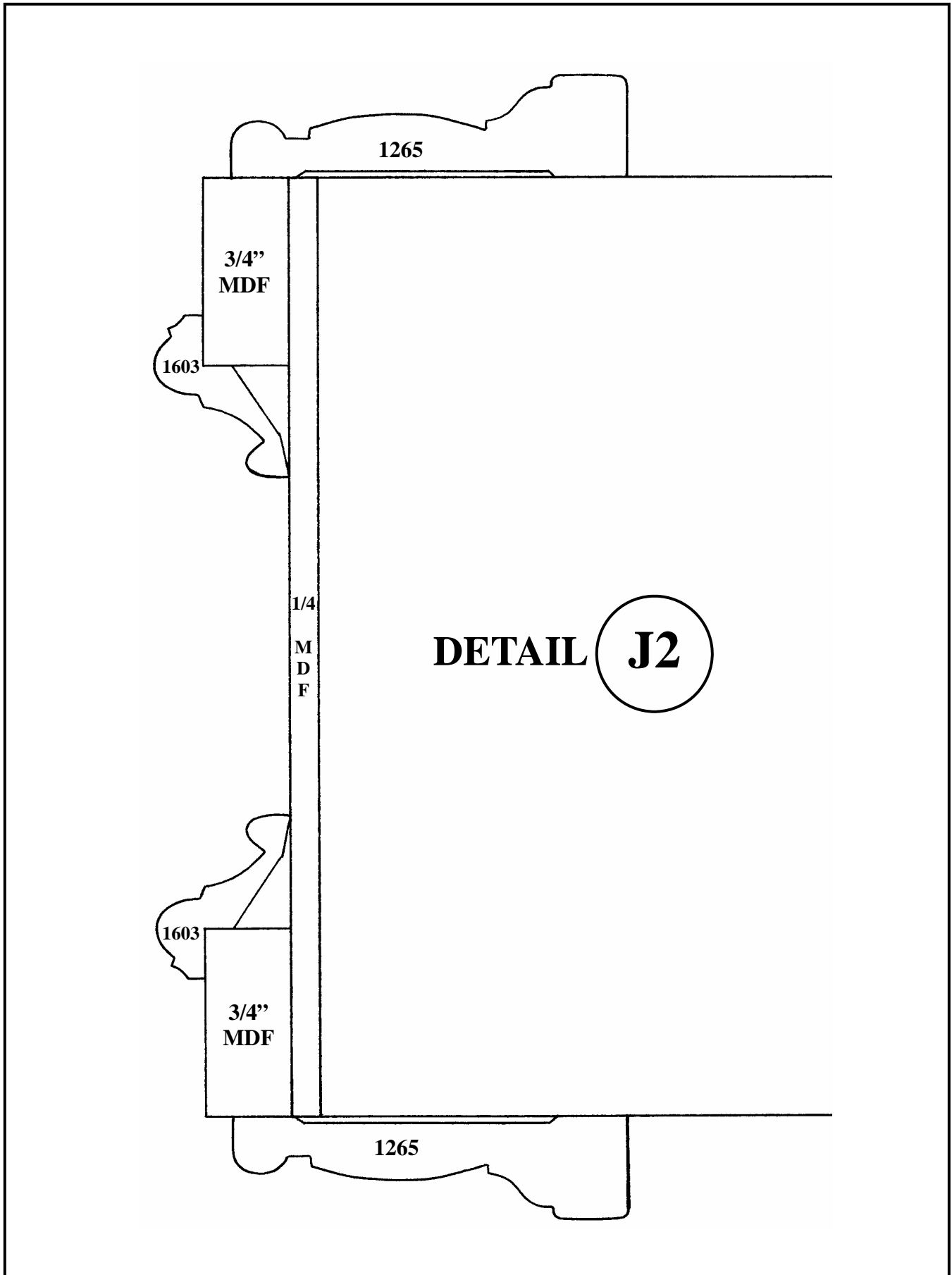

FLAT JAMB DETAIL

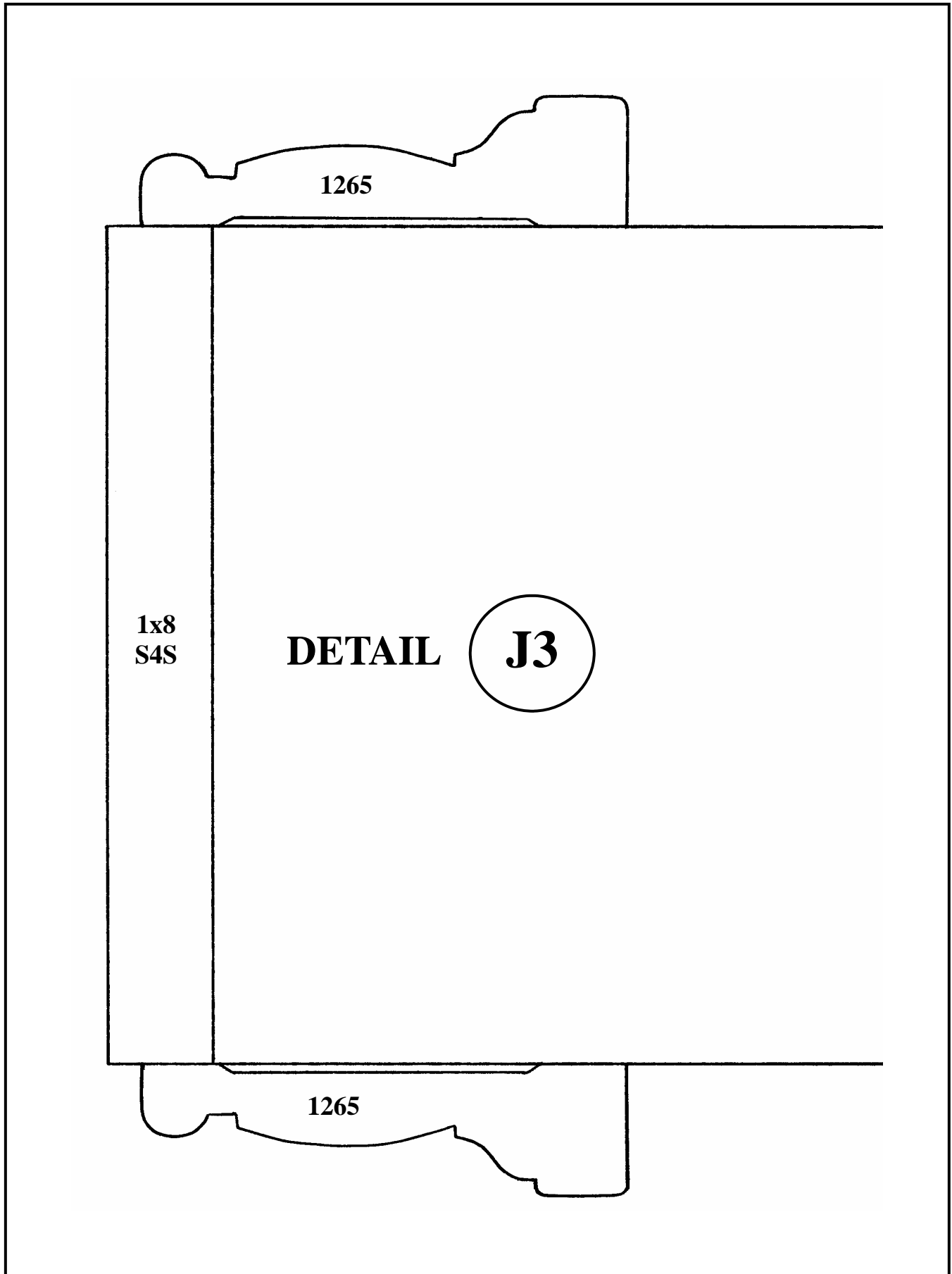

MULLION DETAIL

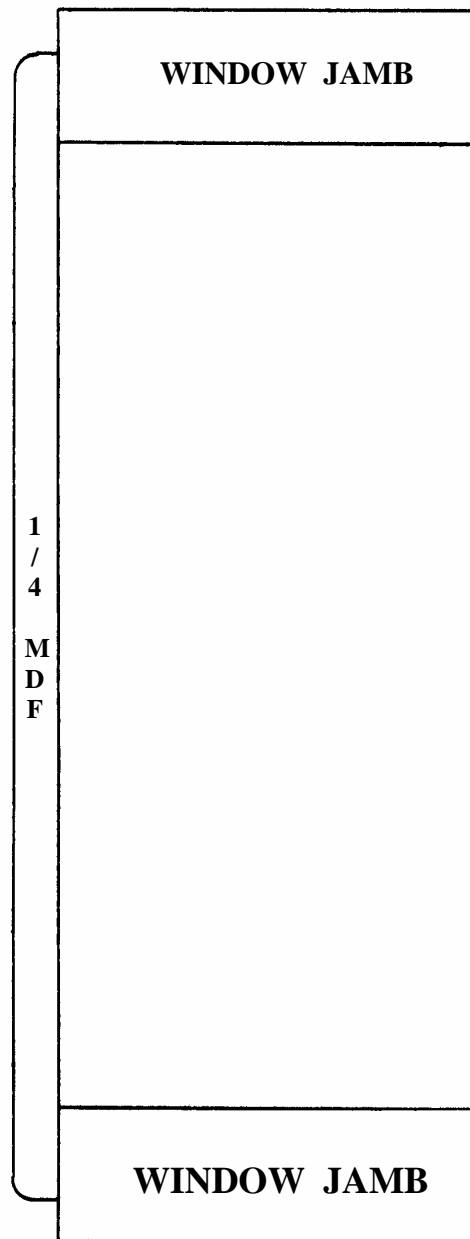

DETAIL

M1

PANELED WAINSCOT DETAIL

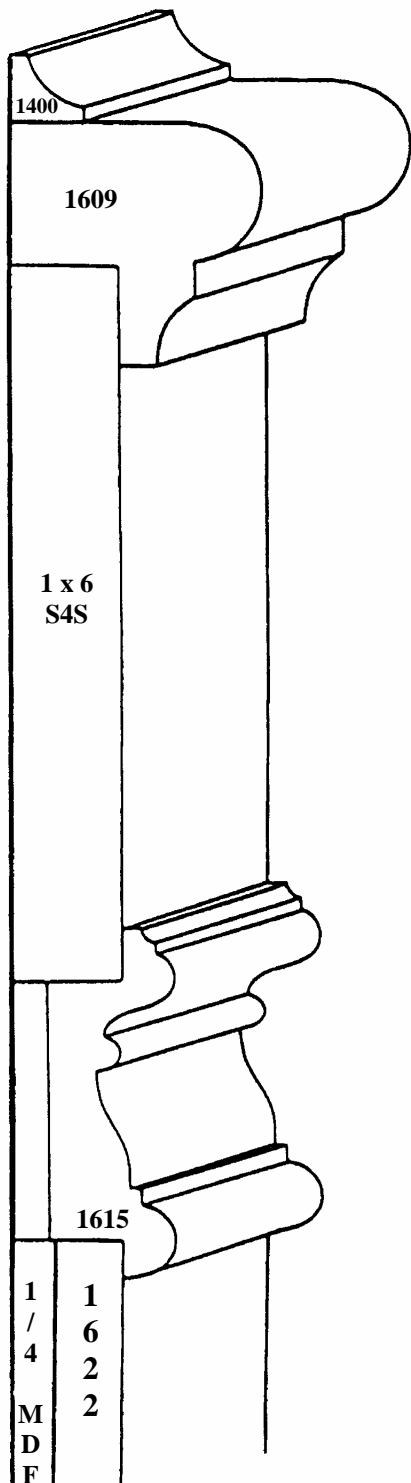

DETAIL

R1

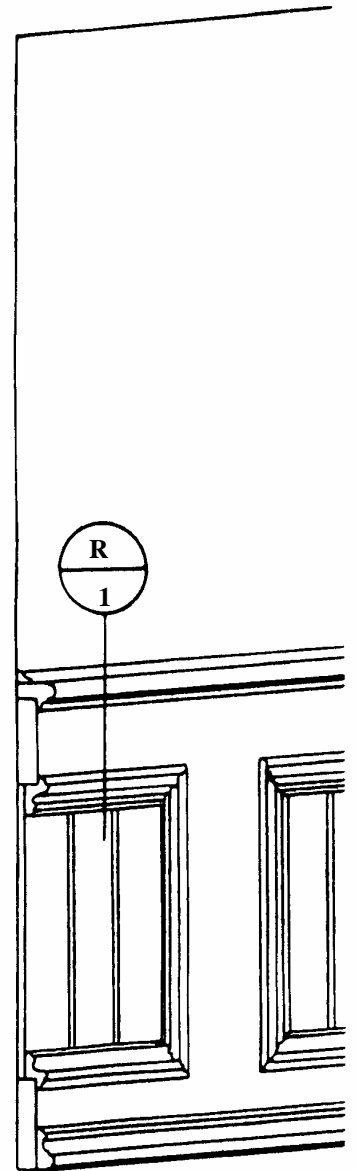

CONCEPTUAL
DRAWING
ONLY

PANELED WAINSCOT DETAIL

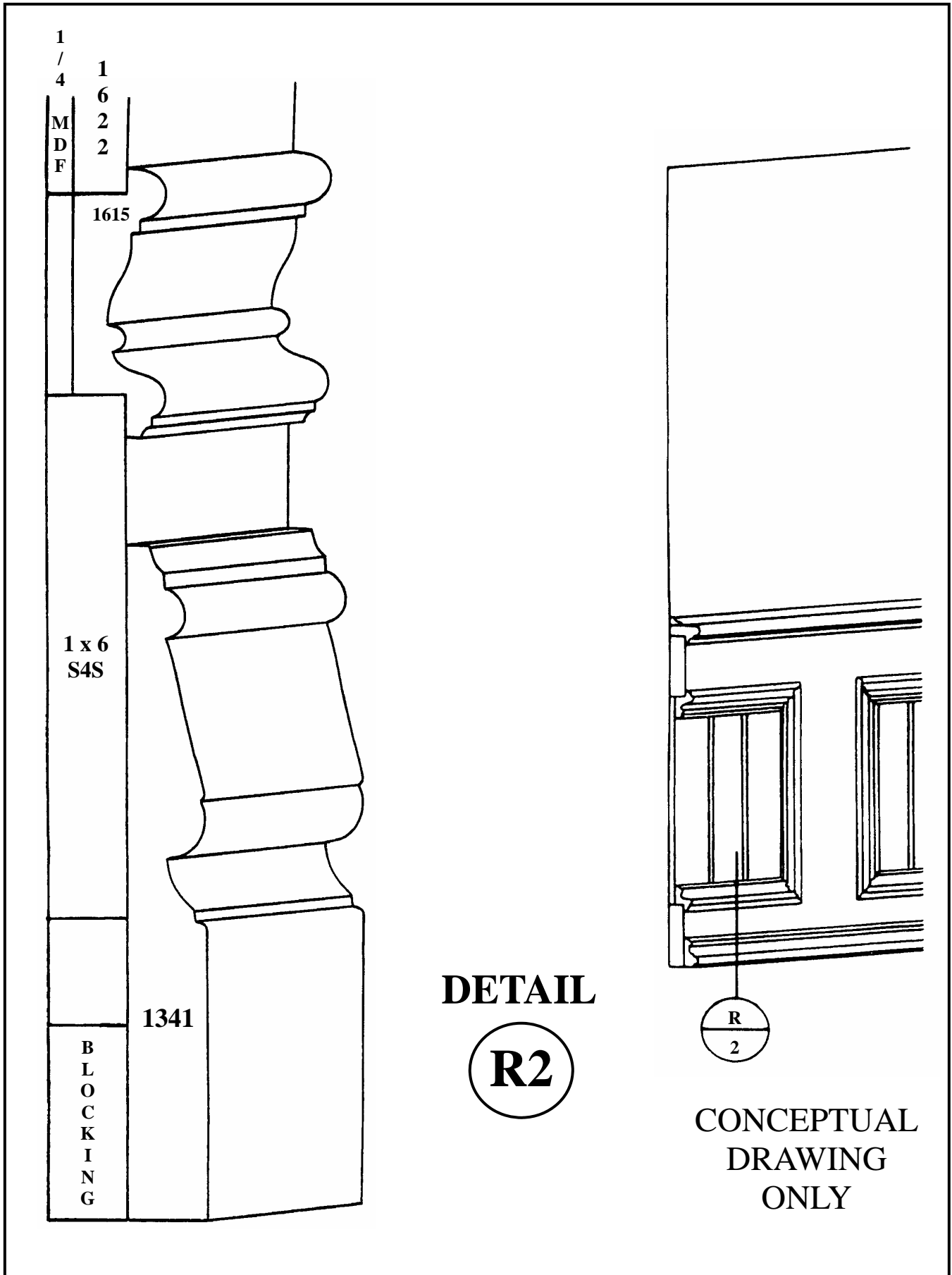

PANELED WAINSCOT DETAIL

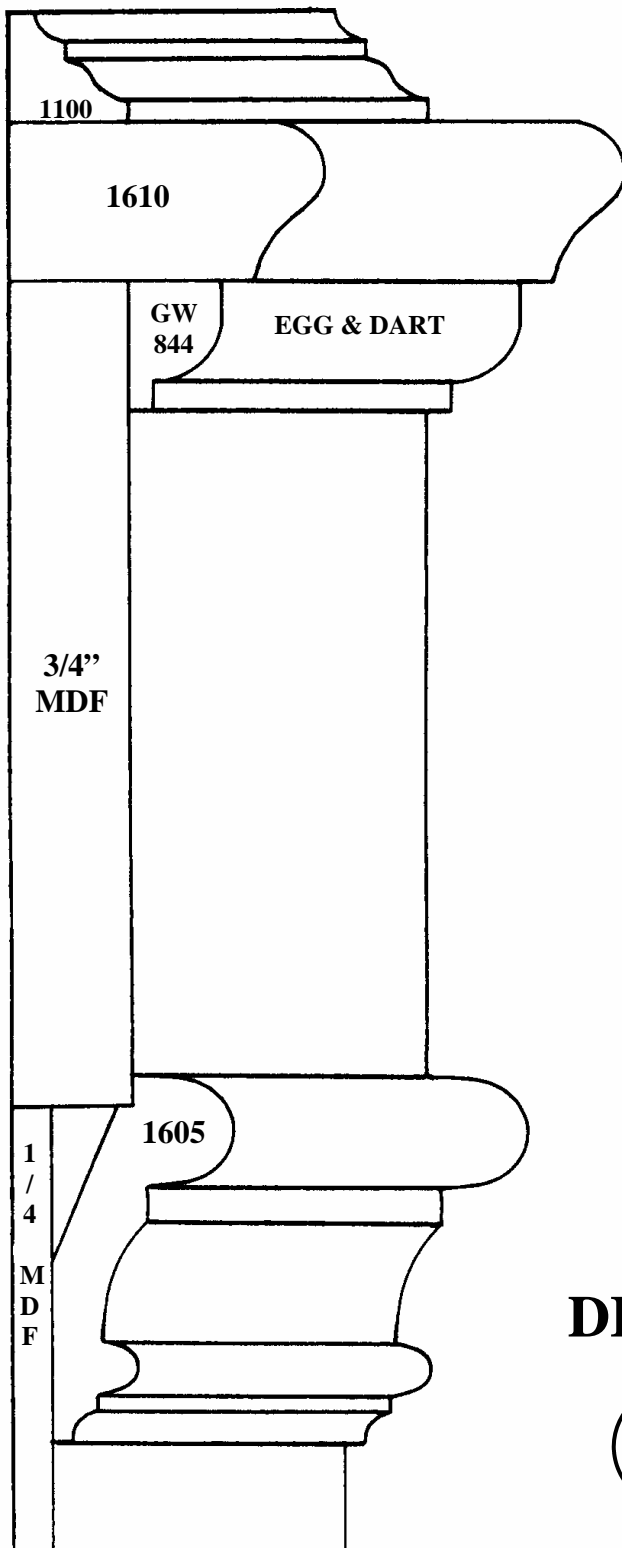

DETAIL

R3

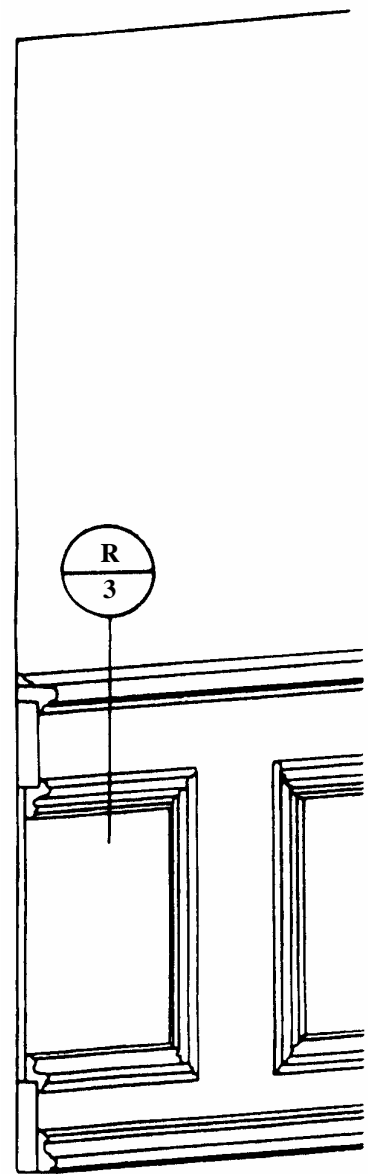

CONCEPTUAL
DRAWING
ONLY

PANELED WAINSCOT DETAIL

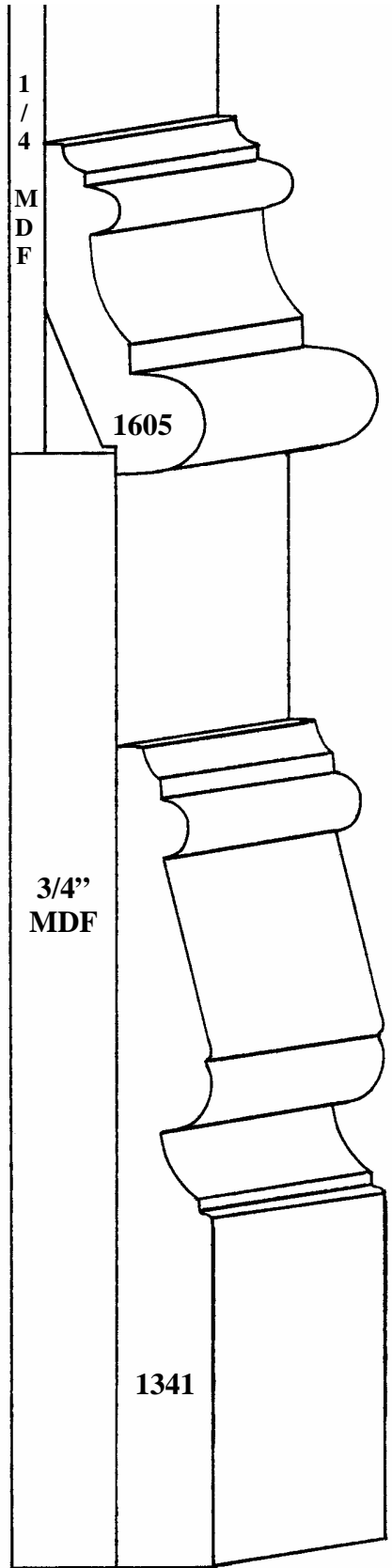

DETAIL

R4

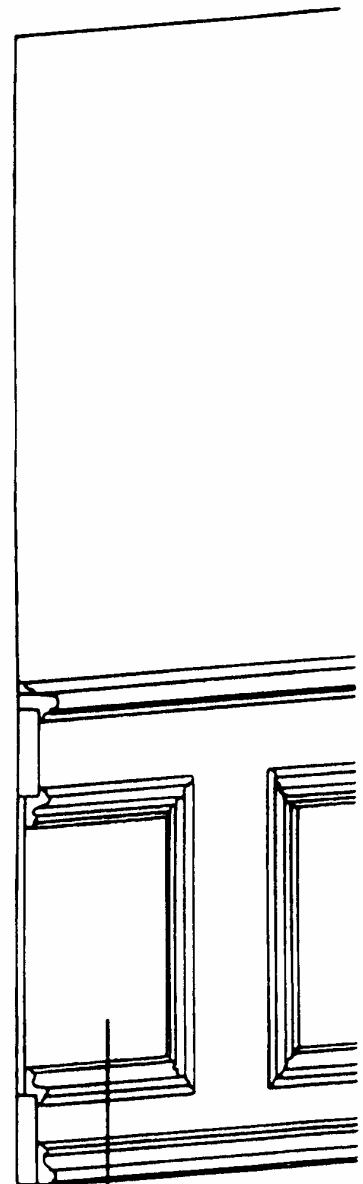

R
4

CONCEPTUAL
DRAWING
ONLY

MOULDINGS USED IN HOME

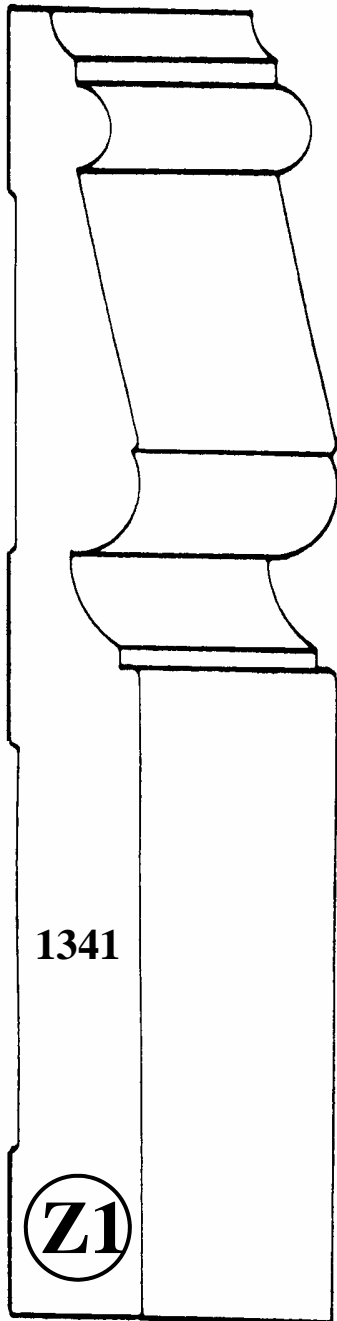

BASE

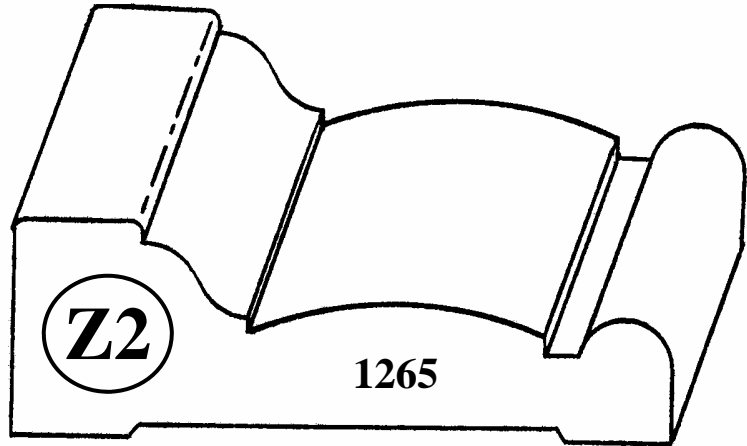

CASING

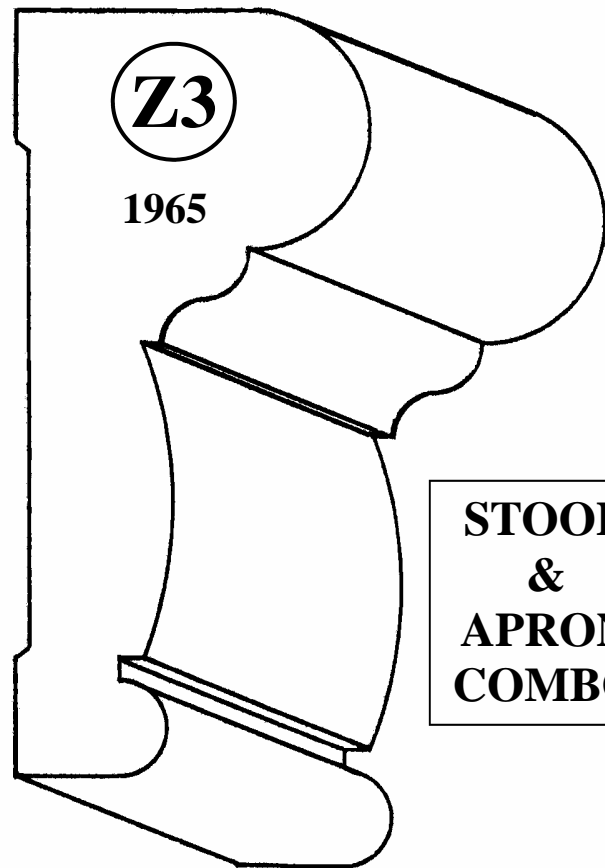

**STOOL
&
APRON
COMBO**